



SAMA Symbols White Paper # 5 – Fuel Addition - Multi Fuel

SAMA Symbols can be easily used to add another boiler fuel to an existing firing rate control system.

With the price of fuel rising, everyone is looking for cheaper and cleaner fuels. SAMA symbols can be quickly used to modify your boiler firing control system to accommodate the addition of another fuel. SAMA stands for Scientific Apparatus Makers Association, the organization that came up with the symbolic language to represent the various pieces of control loop hardware and how they interact together to create a process control scheme.

Assume that the search¹ for natural gas by an independent well driller has uncovered a low quality natural gas well near your plant. The 500 Btu per cubic foot heating value is half the pipeline standard of 1,000 and the driller offers you the well at a low cost since he cannot sell it commercially and your steam boiler is nearby. How could you incorporate this second fuel into your oil burning boiler?

Suppose that your boiler firing control scheme is a full metered system, meaning that it measures both combustion air flow and oil flow. Further assume that it is a parallel control scheme in which independent proportional integral controllers regulate the oil and combustion air flow. Also assume that it is a cross limited scheme which means that the actual oil flow and combustion air flow are tied together in a safe and conservative ratio. And finally these controllers are driven by a boiler steam pressure master controller.

¹ This find of poor quality natural gas is based on a true story from the author's past



If all these assumptions are correct, then the boiler firing rate control scheme would look as follows in SAMA symbols in Figure 1.

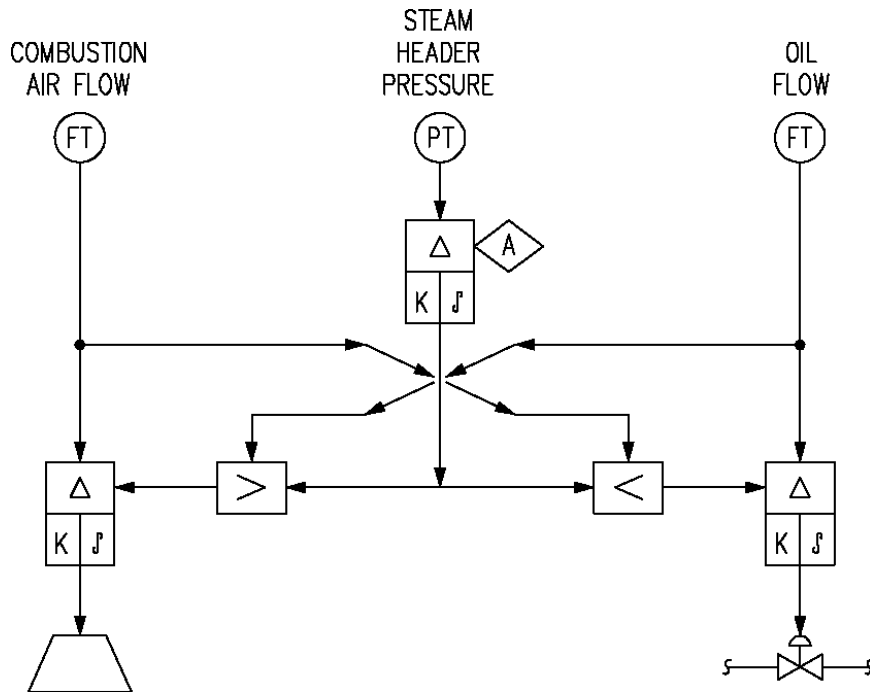

Figure 1

Assume that the boiler can be modified to accommodate a natural gas firing ring and that the boiler safeguards, or burner management system, are modified to accommodate a secondary fuel. What would the firing rate control scheme look like?



Safety is very important in boiler firing so let's start with fuel input and ensure that sufficient combustion air is available to burn all the available fuel. The oil flow and gas flow should be added together to determine the total Btu of fuel to be burned. This can be accomplished by placing a summing block in the fuel and natural gas signals. The equation is simply oil flow times oil fuel heat value, plus natural gas flow times natural gas fuel heat value. The output is total Btu and is used as the cross limiting input to the high select relay for combustion air flow and appears as follows in a SAMA drawing in Figure 2.

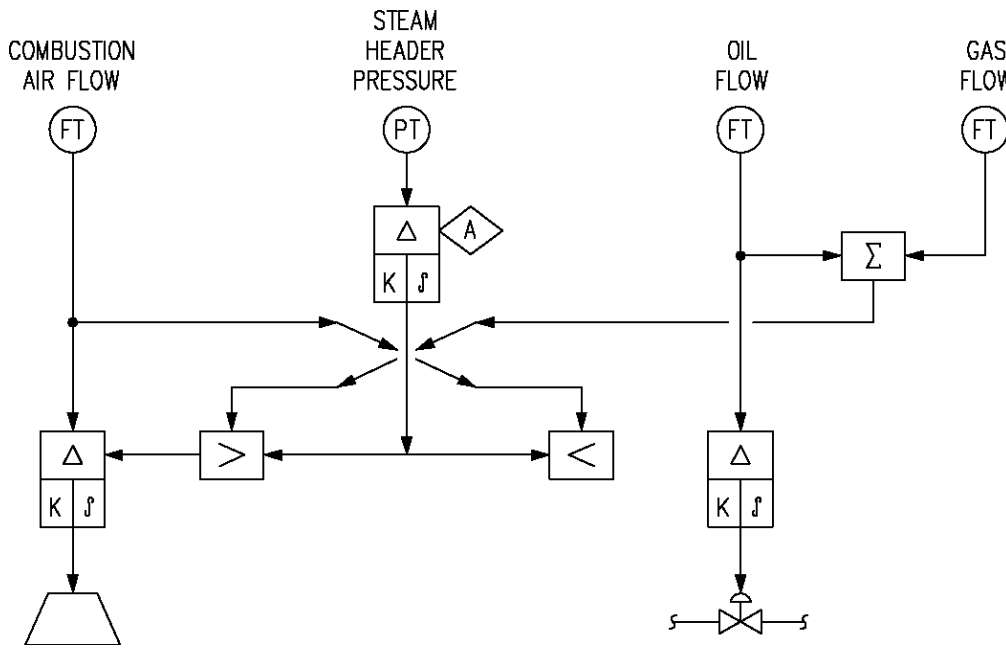

Figure 2

Notice that the oil flow controller remains, however the set point input has been removed because it has to be re-configured. Let's assume that the new supply of off-quality natural gas is variable in Btu content, variable in flow, and subject to interruptions due to the selection of inexpensive wellhead equipment. In this instance, it would be prudent to burn as much off quality gas as possible and let the oil flow fill in the shortages automatically, including curtailment of natural gas. The following control scheme shows how this can be accomplished.

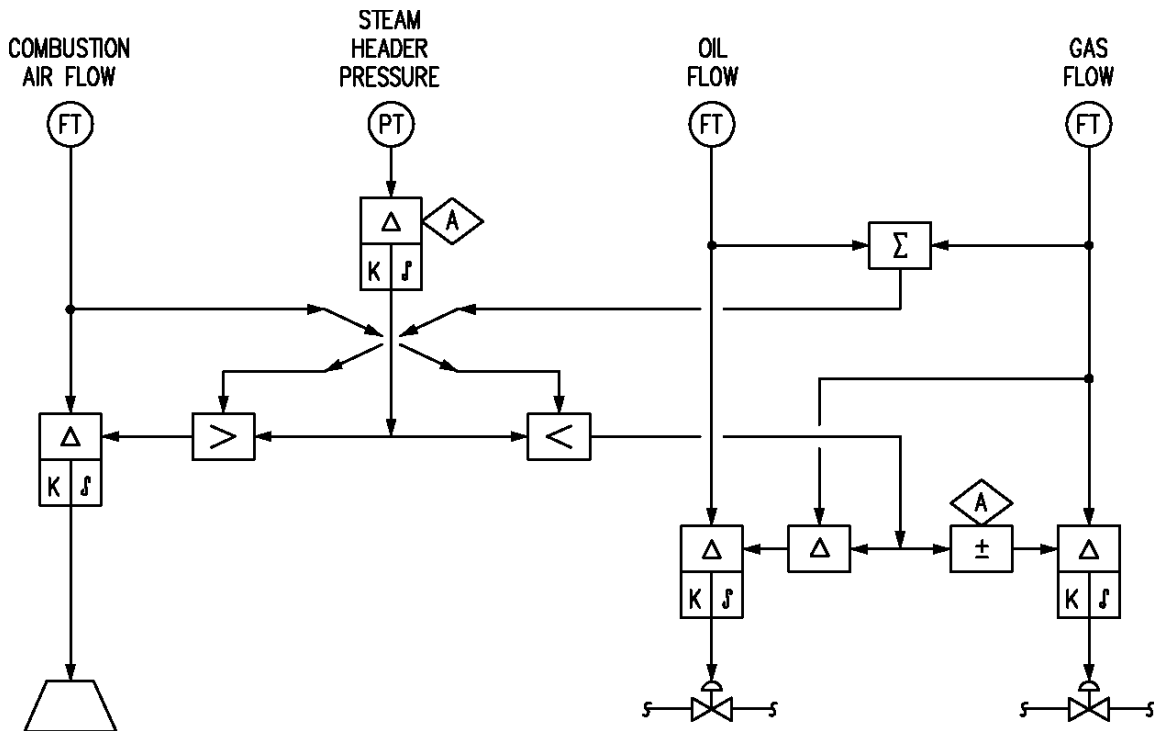

Figure 3

The output of the low select relay is sent to the two fuel flow controllers through some bias and limiting math calculations. The operator would input a manual signal into the bias station for the off-quality gas to burn as much as possible. This maximum flow rate would be learned over time by the process control engineer and the boiler operators. The actual flow of off-quality gas is then used as an input to a difference calculation with the low select relay output. The output is the set point for the oil flow controller to make up the difference. If the flow decreased due to flow or pressure limits, the oil flow would increase. If the off-quality gas stopped flowing completely, then the oil flow would automatically increase to take up the full load.

The use of SAMA symbols has allowed the process control engineer to think through the safety, mass balance, energy balance, and equations involved in developing this control scheme for off quality natural gas. Combustion air flow is sufficient for total fuel flow regardless of source. Usage of off quality natural gas is maximized at all firing rates. Oil flow is minimized and is maintained in automatic standby in the event of natural gas interruption.

We will focus on Oxygen trim next in our sixth article of a nine part series on SAMA symbols.



This article on SAMA Symbols was written to convey the power, elegance, and ease of designing complex control schemes. This article is not a full, complete, or correct design of any control system. The reader shall retain the services of a licensed professional engineer with extensive process control experience. The professional engineer must first analyze the specific process in question. As my college professor used to say, “You can’t design a control system until you understand the process.”

Copyright © 2009 by Green Energy Engineering, Inc.

Eric Coffin, Registered P.E. - Florida, is president of **Green Energy Engineering, Inc.**, a company focused on solutions that can reduce the amount and cost of purchased energy.

He has a Bachelor’s degree in Mechanical Engineering with an emphasis on Thermal Processes, Process Control, and Fluid Flow.

Coffin is a certified energy manager worldwide and is an approved Professional Engineer Continuing Education provider in many states.

For more information, visit www.GEEintl.com

