



### **SAMA Symbols White Paper #1 – Why Use Them?**

*What are SAMA Symbols and how can they be used to make complex control schemes easy to understand?*

SAMA stands for Scientific Apparatus Makers Association, the organization that came up with the symbolic language to represent the various pieces of control loop hardware used in boilers and how they interact together to create a process control scheme.

Industries and utilities alike are renewing their emphasis on boiler efficiency, energy savings and lower emissions levels, as reducing their “carbon footprint” takes on greater importance. Engineers are analyzing the control systems and instrumentation for boilers, and putting on paper the complex processes and interactions that make boilers function.

Some may be doing it to add a renewable energy to the mix to increase overall output, to meet regulatory requirements or to receive tax rebates from government. This focus on a “green” energy-producing environment has led to a revival of interest among process engineers and others in the old and esoteric notations called SAMA symbols.

SAMA symbols are used to develop and convey the complex functional interworking of boiler control loops. The four most common control loops used in industry are temperature, pressure, level, and flow loops. Each of these loops is comprised of just three devices: a transmitter, controller, and control valve. These are simple single loops with just one feedback signal. However, boiler controls involve many transmitters, many feedback signals, feedforward, cascade, and parallel functions.

Sam G. Dukelow, author of the classic textbook, The Control of Boilers,<sup>1</sup> explains further, “A boiler control system is an interconnected package of control loops and functions into which a number of inputs are connected and a number of output signals are delivered to final control devices. A change from one input will usually affect more than one output. In addition, a change in one output may have an effect on more than one boiler measurement or input. Because of this, the specific arrangement of control equipment has a very significant effect on control interaction. It is a goal in the improvement of this type of control system to minimize these interactions. This requires the development of control logic that will not only perform these control logic functions but will also minimize the interaction between control loops.”

---

<sup>1</sup> The Control of Boilers, Second Edition, Page 3, , Section 1, Introduction, Copyright © 1991 by ISA



Simple feedback control loops can be represented and understood on most drawings. For instance, the Instrument Society of America presentation of a temperature control loop could be represented on a Piping & Instrument Diagram (P&ID) as shown in Figure 1 below.

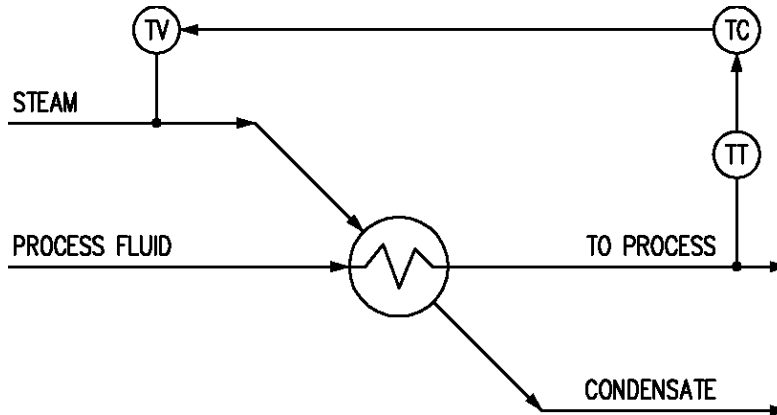

Figure 1

It is clear from this P&ID that the steam control valve (temperature valve, or TV) is being regulated by the temperature controller (TC) in order to increase and maintain the process fluid temperature measured by the temperature transmitter (TT).

A SAMA symbols representation of this same temperature control loop would look as follows in Figure 2:

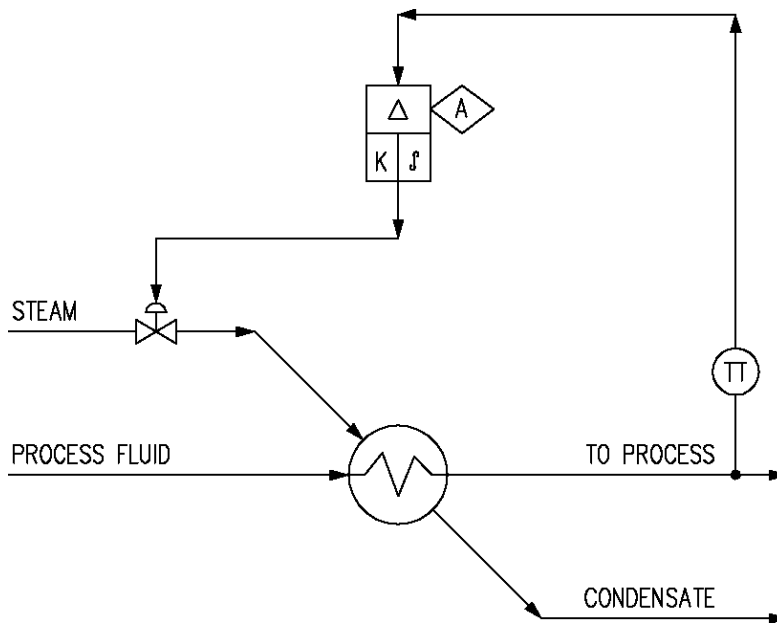

Figure 2

For more information, contact **Eric Coffin** at **727-742-7276**  
or visit **www.GEEintl.com**



The temperature transmitter (TT) would remain as represented before. The temperature controller would now be represented by the SAMA symbol for a two-action (proportional and integral) controller. The feedback signal, or process variable (PV), is shown coming from the TT and into the top (or back) of the controller. The set point (SP) is shown coming into the side of the controller from the manual diamond with the A inside. The delta  $\Delta$  symbol is used to indicate the calculation of error between the desired SP and the actual measured PV. The K symbol is used to represent gain or proportional action. The  $\int$  integral symbol is used to represent the integral or reset action of the controller. The third action, not shown here, would be derivative and would be represented as  $d/dt$  in a third vertical box beside the other two. The final control element is the steam control valve and is represented as such.

While this simple single feedback temperature control loop can be represented and understood in either drawing format, the following three-element boiler drum level control scheme, shown as part of a P&ID in Figure 3, is more readily communicated with SAMA symbols.

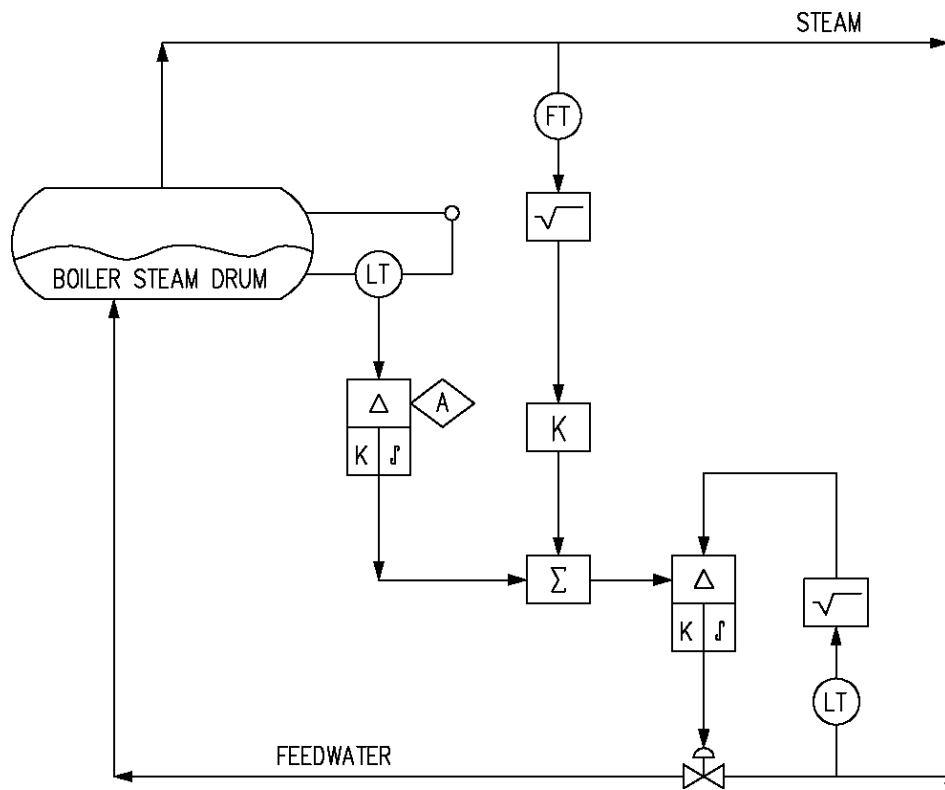

Figure 3

Here the shapes help to differentiate between transmitters, math functions and true controllers. It is clear that there are three transmitters and one final control element or control valve. Moreover, the drum level controller output is cascaded into the feedwater controller. Also notice that the steam flow serves as a feedforward signal to the same feedwater controller.



This version of the boiler three-element drum level control can also be removed from the P&ID and shortened into the following SAMA control drawing shown in Figure 4 for even more understanding.

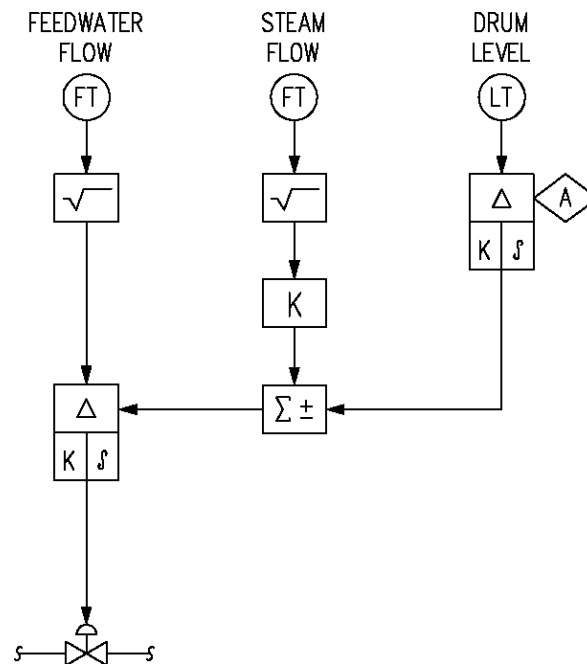

Figure 4

The SAMA control drawing above, of the boiler three-element drum level control scheme, clearly shows the three transmitter inputs across the top and the final control element, feedwater control valve, on the bottom. This represents four wired connections from the control room to the field devices. The interior of the drawing shows the two control functions and the four math functions. Moreover, note the five “rubber” wire or software connections that exist within the control hardware. This is a typical SAMA symbols drawing showing the boiler control drawing of a three-element drum level control scheme.



Three-element drum level control can also be done as a mass balance as shown in Figure 5 below:

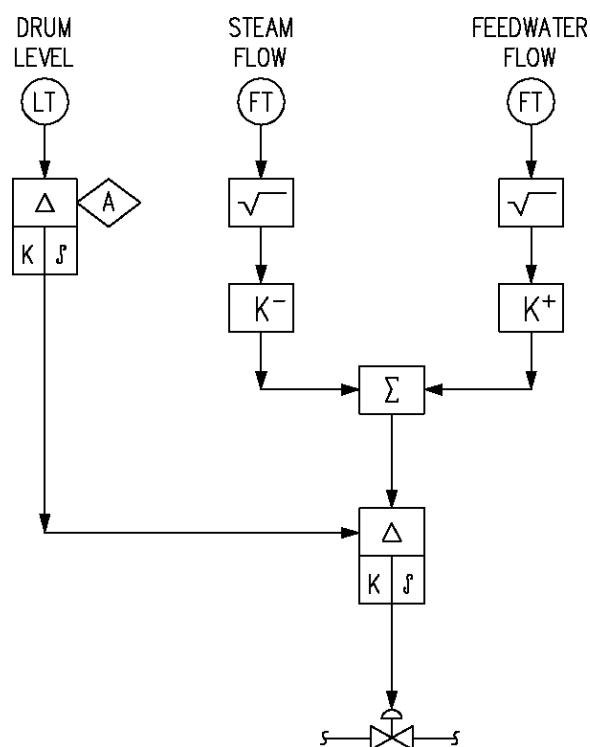

Figure 5

This mass balance approach allows the feedwater flow to closely track the steam flow with correction from the drum level controller. The  $K^-$  and  $K^+$  allow the designer to match the ranges of the two different flow meters. The square root function is typical of orifice plates and would not be needed if vortex meters or turbine meters were used.



Three-element drum level control can also be enhanced with pressure compensated drum level, pressure compensated feedwater flow, and pressure and temperature compensated steam flow as follows in Figure 6:

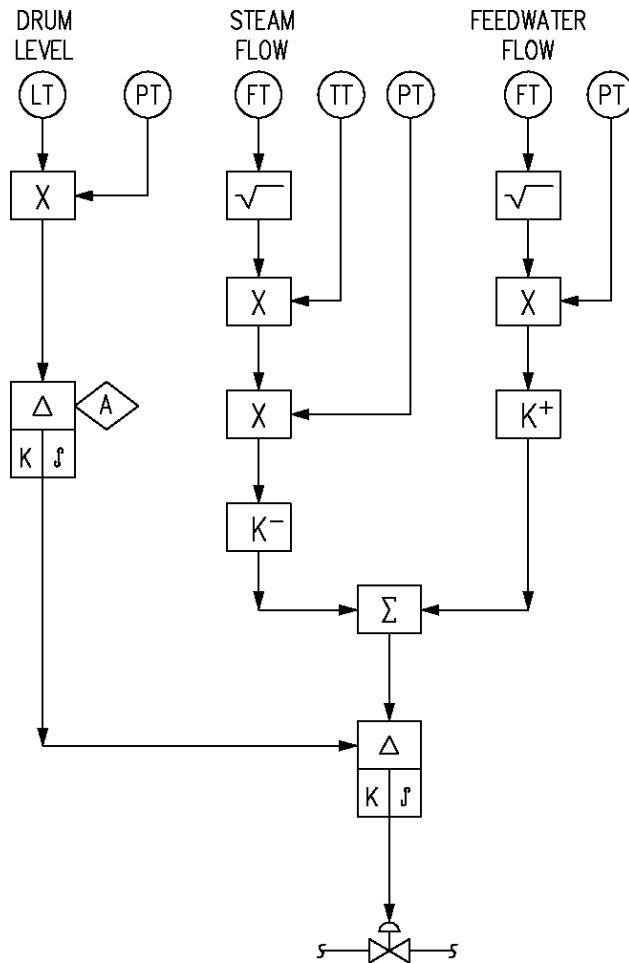

Figure 6

This temperature and pressure compensated control scheme is very easy to understand. The process control engineer and / or the instrument designer can easily set up the required equations and program them into the correct control blocks.



The following SAMA symbol drawing Figure 7 is a five-element drum level control. Once again it is clear that the blowdown signal is subtracted from the feedwater signal to compensate for the lost water. The fuel flow is yet another feedforward signal alerting the feedwater controller of a load increase or load decrease.

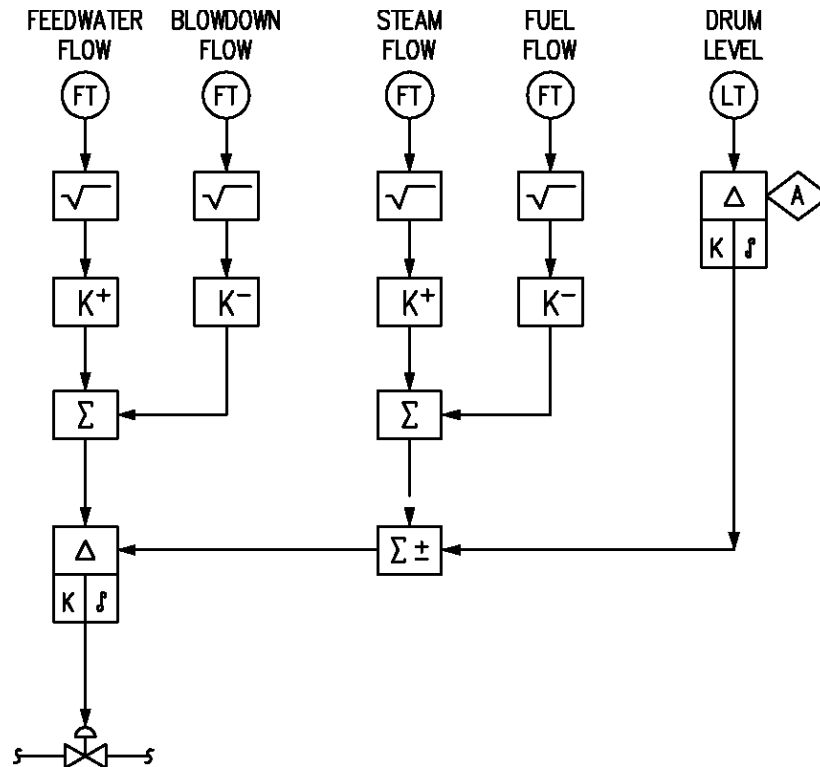

Figure 7

This white paper has clearly shown that SAMA symbols are a powerful tool in developing and communicating boiler control schemes. The process engineer and control engineer can easily use this tool to develop the required control scheme; the blocks lend themselves to easy naming and development of the math equations needed to add, subtract, multiply, and divide. This SAMA symbols layout is an excellent communication document to pass on to the instrument engineer tasked with specifying transmitters and final control elements. Moreover, the functional layout makes it easy for the control system vendor to propose, price, and program the distributed control system. In the next article in the series we will discover that SAMA symbols are a process control language.



This article on SAMA symbols was written to convey the power, elegance, and ease of designing complex control schemes. This article is not a full, complete, or correct design of any control system. The reader shall retain the services of a licensed professional engineer with extensive process control experience. The professional engineer must first analyze the specific process in question. As my college professor used to say, “You can’t design a control system until you understand the process.”

Copyright © 2009 by Green Energy Engineering, Inc.

**Eric Coffin, Registered P.E.** - Florida, is president of **Green Energy Engineering, Inc.**, a company focused on solutions that can reduce the amount and cost of purchased energy.

Eric has a Bachelor’s degree in Mechanical Engineering with an emphasis on Thermal Processes, Process Control, and Fluid Flow.

Coffin is a Certified Energy Manager worldwide and is an approved Professional Engineer Continuing Education provider in many states.

For more information, visit [www.GEEintl.com](http://www.GEEintl.com)



---

For more information, contact **Eric Coffin** at **727-742-7276**  
or visit **www.GEEintl.com**

---